

Nuclear Valves

Needle Valves, Ball Valves and Manifolds

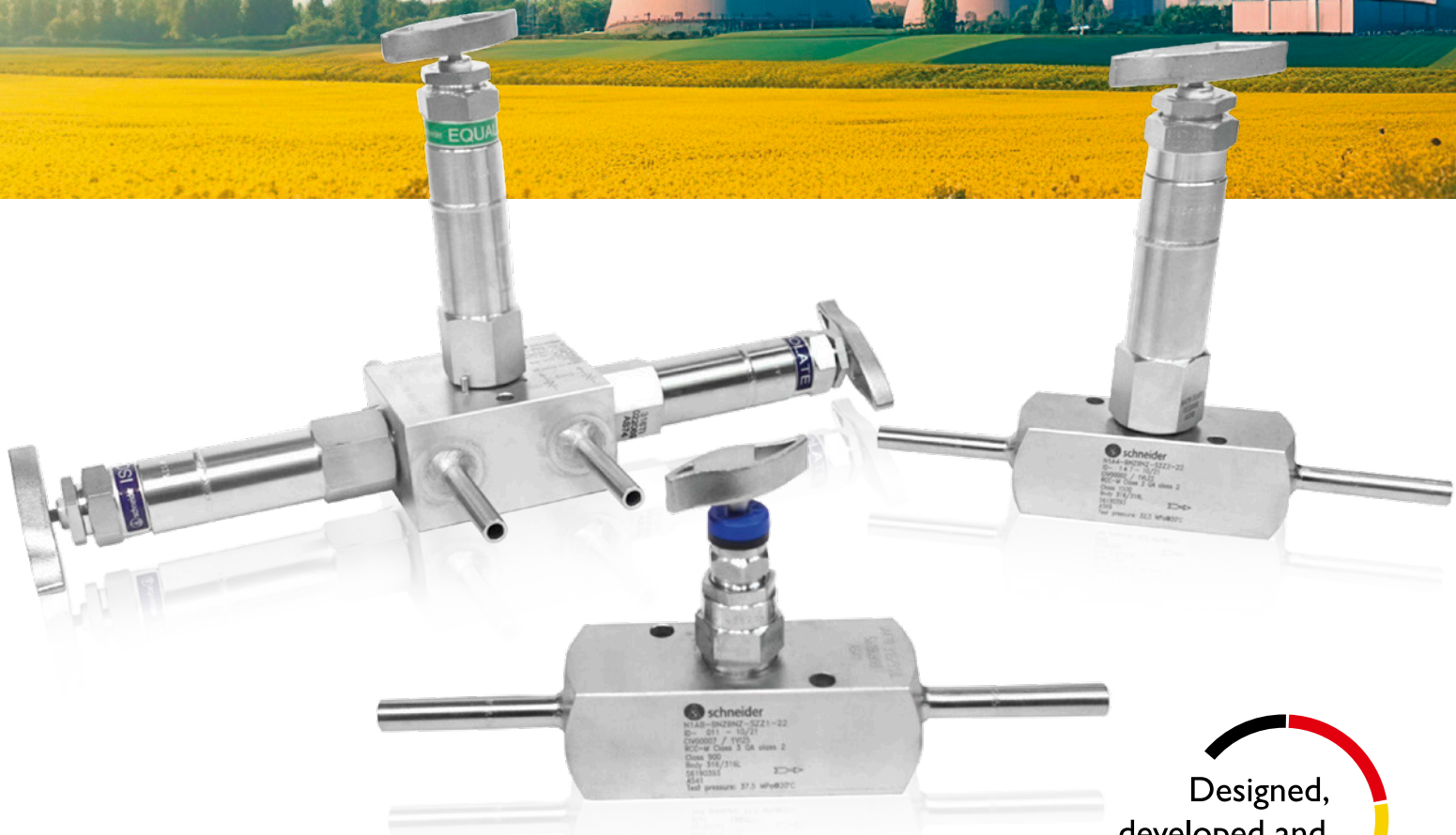

Designed,
developed and
made in Germany

Introduction

Introduction

The AS-Schneider Group with its headquarters in Germany is one of the World's Leading Manufacturers of Instrumentation Valves and Manifolds. AS-Schneider offers a large variety of any kind of Valves, Manifolds and the relevant Accessories required for instrumentation installations globally.

We have around 40 years of experience in the development, production and sales of products for fossil-fuelled power stations and have been developing valves for nuclear power stations for more than 20 years. We are supplying bellows sealed valves to power stations for more than 40 years. Our especially for the nuclear service prepared valves and manifolds are installed in different nuclear plants globally.

Continuous product development may from time to time necessitate changes in the details contained in this catalogue. AS-Schneider reserves the right to make such changes at their discretion and without prior notice.

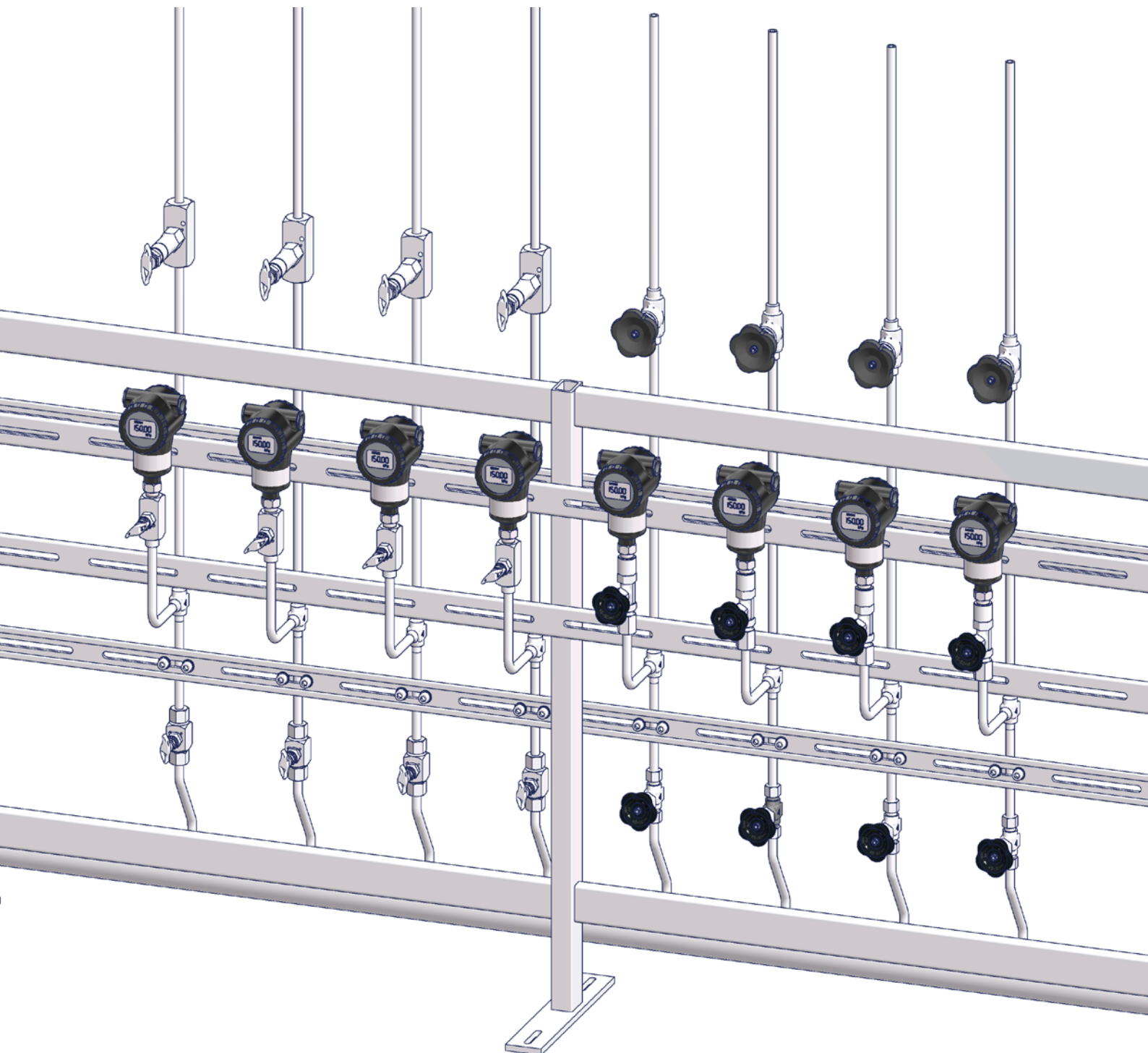

Introduction	page 2
Contents	page 3
Valve Head Unit Bellows Sealing	page 4
Valve Head Unit Packing Sealing	page 5
Ball Valve	page 6
Design Examples	page 7
Quality Assurance / Recent Projects	page 8-10
Notes	page 11

Valve Head Unit Bellows Sealing

Valve Head Units for technically leak-tight Applications

Bellows Sealed Head Units

Screwed Bonnet – PN 100 and Graphite Safety Packing
PN 250 and Graphite Safety Packing

Features

- Integral Valve Seat – Metal to Metal Seated
- Non-rotating Stem
- Bellows sealed – PN 100 and PN 250 incl. Graphite Safety Packing
- Stem with cold rolled threads
- Bellows are submitted to a 100% Helium leak test
- Leak rate: 10^{-8} mbar l/s

Bellows Sealed Head Units are mainly used for applications requiring the highest tightness class – such as toxic, vacuum or nuclear services

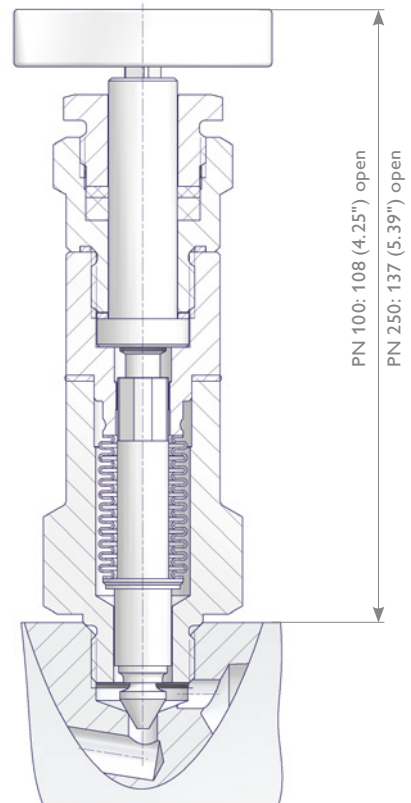

Pressure-Temperature Rating

Bellows PN 100 Safety Packing Graphite
Bellows PN 250 Safety Packing Graphite

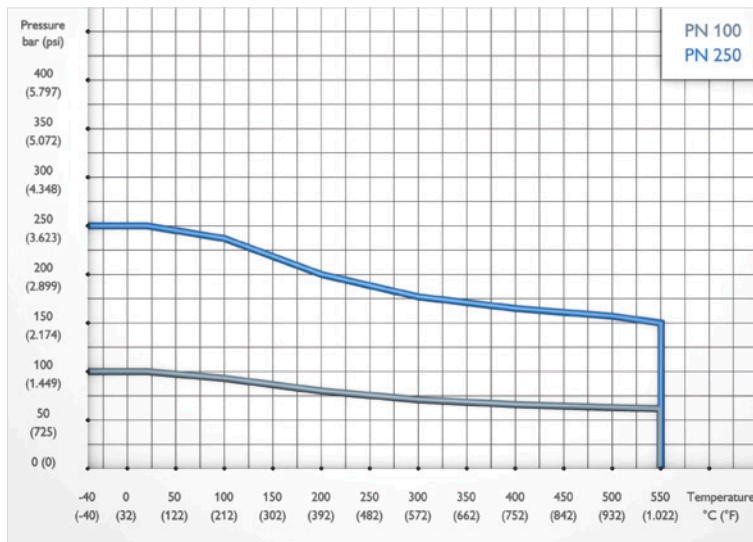

Above-mentioned Pressure-Temperature Rating is based on the standard material 316 stainless steel.



High Temperature version on special request also available.

Valve Head Unit Packing Sealing

Standard Needle Valves

Screwed Bonnet – Stem Seal: Packing

Features

- Metal Seated
- Non-rotating Needle
- External Stem Thread – Packing below stem threads. Stem Threads are protected from process media (non-wetted), helps to prevent stems from galling.
- Stem with cold rolled threads
- Blow-out proof Needle
- Back Seat – Metal to metal secondary needle seal
- Lock Pin – Eliminates unauthorized removal of the bonnet
- Color Coded Dust Cap for operating thread protection
- Packing Graphite
- Max. allowable (Working) Pressure (PS):
420 bar (6,092 psi)
– 689 bar (10,000 psi) optional
- Panel Mount Option available
- Anti-Tamper Valve Head Options available
- All non-wetted parts in 316 stainless steel

Standard Design
420 bar (6,092 psi)

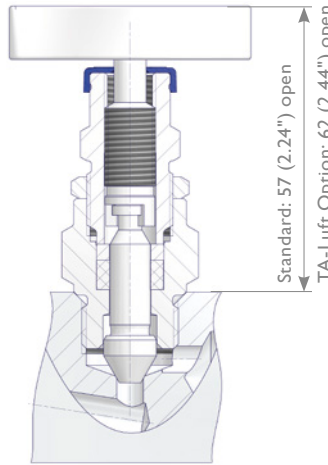

High Pressure Design
689 bar (10,000 psi) and
500 bar (7,252 psi)

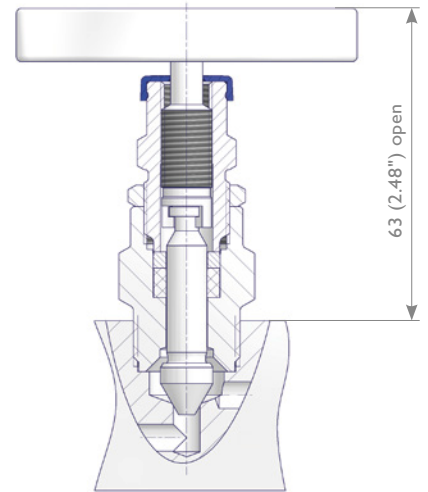

Body-to-Bonnet Seal is below the threads eliminating process fluid corrosion.

Pressure-Temperature Rating

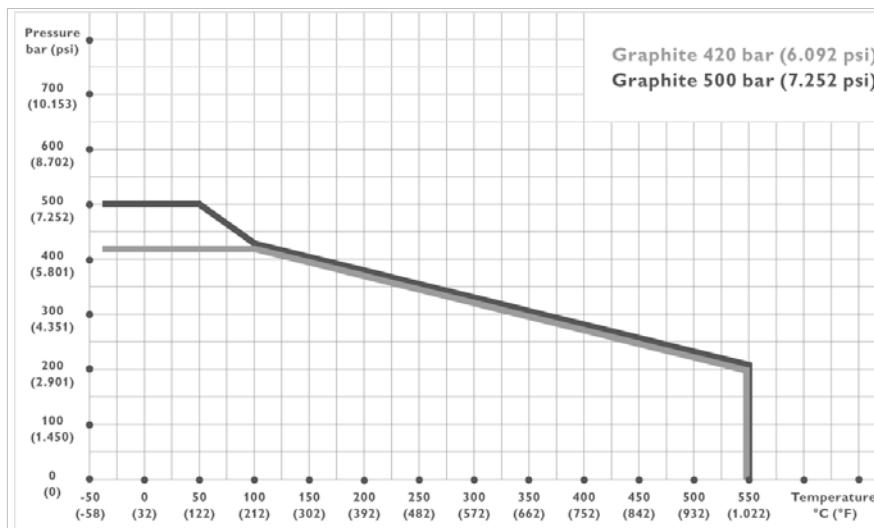

Above-mentioned Pressure-Temperature Rating is based on the standard material 316 stainless steel.

Ball Valve

K Series Ball Valves

AS-Schneider's K Series Ball Valves are very robust ball valves which are designed especially for severe service for the chemical and petrochemical process industry. End connector and valve body are full penetration welded for environmental protection. Thus enable them perfect for the usage in nuclear services as well.

Features

- Floating Ball Design
- 2 Piece Design – Fully Welded
- Ball Bore Size 10 mm (0.39")
- Ball Seats are encapsulated in Seat Carrier
- Stem Seal Graphite
- Max. allowable (Working) Pressure (PS): 250 bar (3,626 psi) | Class 1,500
- Anti-Blowout Stem Design
- Low Operation Torque
- Fire Safe tested acc. to ISO 10497 / API 607
- Wide Range of Connections available
- Pressure Test acc. to EN 12266 and MSS SP61 – Leakage Rate A acc. to EN 12266-1
- Seat Leakage Class VI acc. to ANSI/FCI 70-2
- Materials comply to NACE MR 0175 / MR0103 / ISO 15156
- Ergonomic Oval Handles – Can be locked in opened and closed Position
- Anti-Static Design

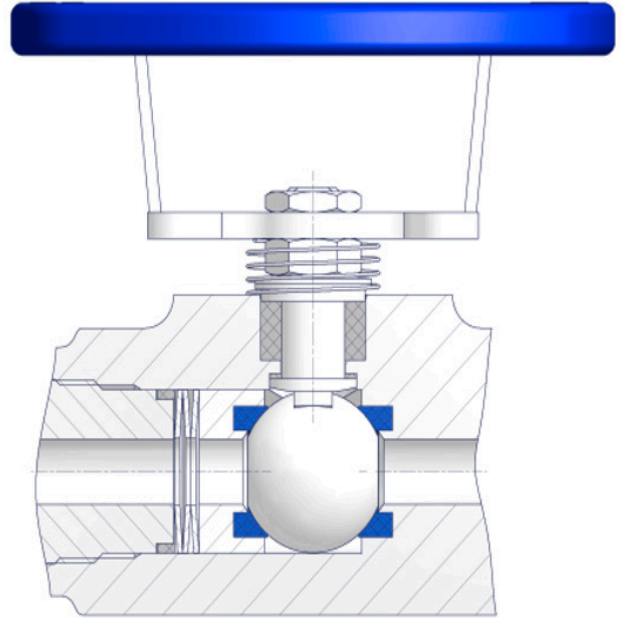

Optional Features

- Padlock for Lockable Handle
- Extended Stem

For further Details, please contact the factory.

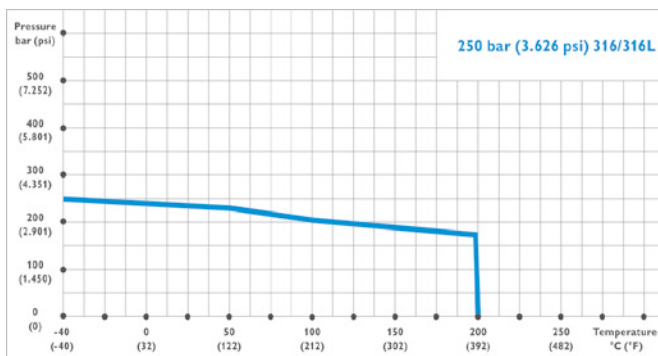

Components	Carbon Steel	Stainless Steel
	Material / Material No.	
Body	1.0460 / A105	316 / 316L
Body End Connector		
Ball		
Stem	316 / 316L	
Seat Carrier	316 / 316L	
Disc Spring	Inconel 718	
Primary Stem Seal	PEEK 450G	
Ball Seat	PEEK 450G	
Packing	Graphite	
Body Seals	Graphite	
Gland	316	
Hex Nut	300 Series	
Locking Plate	300 Series	
Oval Handle	300 Series	
Handle Grip	Vinyl	
Stop Screw	A2	

Wetted components listed in **bold**.

Design Examples

5-Valve Bellows Manifold – Welding Ports

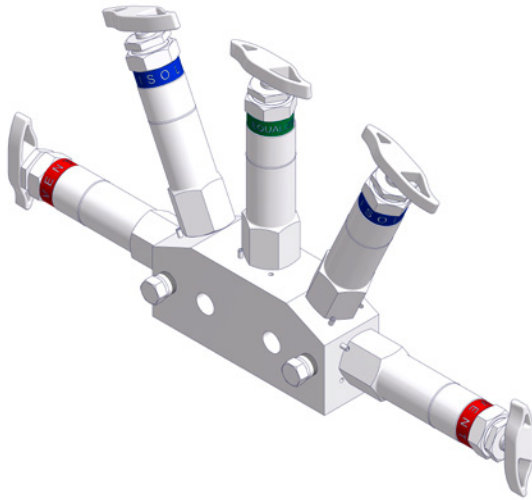

3-Valve Graphite Manifold – Tube Ending

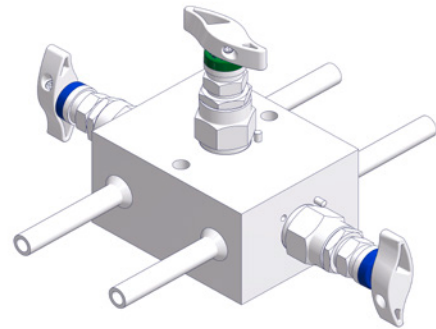

Forged Needle Type Globe Valve

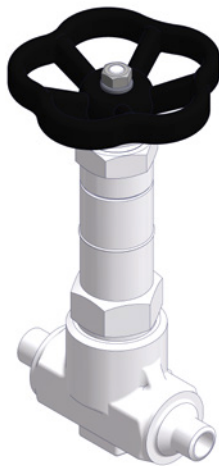

Forged 3-Valve Needle Manifold



Bolted Bonnet Needle Valve

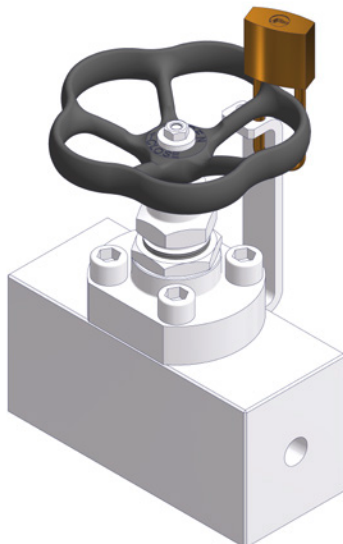

Single Bellows Valve – Tube Fittings

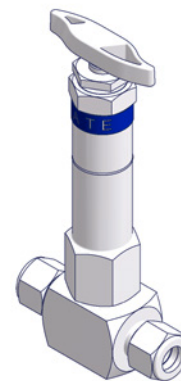

The above shown designs are a few examples only. Is your desired design not included, pls. contact the factory for further guidance? For further information please contact the factory

Certification and Standards

AS-Schneider always follows the latest international standards and requirements. All our acting is to assure the best possible process, product and service quality.

Our Valves and Manifolds are designed, tested and certified in accordance with internationally relevant standards.

Your Benefits at a Glance

- ISO 9001:2000 and ISO 14001:2015
- DIN EN ISO 3834-2
- AD 2000-Merkblatt HP 0 / W0 / TRD 100 in accordance with Pressure Equipment Directive 2014/68/EU
- Pressure Equipment Directive (PED) 97/23/EC Module A1, C1, B
- Fire Safe acc. to ISO 10497 / API 607 with Graphite Packing
- Fugitive Emission Type Tested acc. to ISO 15848 / TA-Luft
- CRN Registration
- TR-TS (EAC) certificate for customs union (Russia, Belarus, Kazakhstan) - formerly GOST-R
- KTA 1401
- HAF 604
- DVGW Approvals
- Current state of the art
All designs correspond to the current state of the art technology!
They have been designed and continuously developed using the latest design and simulation methods coupled with decades of experience.
- High-Quality Raw Materials sourced from Europe or North America.



Applied Standards

DIN, EN, ISO, ASME, ASTM, API, MSS, AD-2000, RCC-M and other criteria dependent on our customers' demands.



Designed,
developed and
made in Germany

Production

Our high automated production facilities with latest production technology allow us to guarantee the production of high-quality products.

Our wide range and extensive depth of fabrication, along with our ultra-flexible production methods, allow us to meet nearly all of our customer's requirements entirely in-house.

Thanks to the quick setup of our production facilities, we guarantee not only cost-effective series fabrication but also the timely, high-quality production of customer-specific individual orders.

lean - AS-Schneider Lean Process

The consistent use of lean tools and methods helps us organize our processes efficient and sustainable. As a result, we can guarantee our customers high product quality and short cycle times.

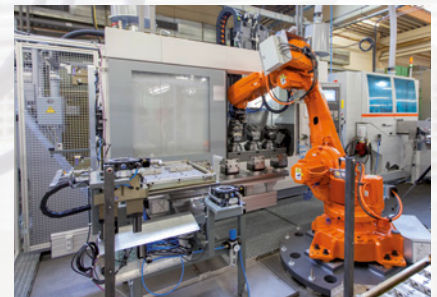
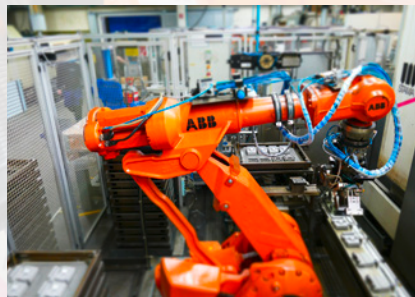

Satisfied Customers are our Objective

It starts with the purchasing of high quality materials only. A flexible planning and our state of the art production ending in a high quality product. Even after a successful installation, our service doesn't end. In the unlikely case and you would need an after-sales service, you are always welcome.

Continuous quality monitoring in our test laboratory guarantees compliance with strict standards. Thus, leads into the best functionality and long-term reliability of our valves.

State of the art methods and continuous audits from different association ensure our high quality level.

In frequent workshops we steady work on us to improve our delivery performance as well as our inquiry and complaint management.

All the employees of AS-Schneider contribute responsible at their posts to ensure that the quality of our products and services meet our own high expectations.

Processes are clearly defined, optimized working areas and a transparent communication between departments and colleagues.



Quality Assurance / Recent Projects

Testing

Valves and manifolds supplied by AS-Schneider have passed various testing so we ensure to fulfill 100% of your needs.

Strength & Tightness testing

Standardized done acc. to DIN EN 12266 or acc. customer demands.

Helium

Various helium testings are possible. We can do sniffing, vacuum or bubble testing.

Seismic

In collaboration with another global market leader we prove our products against seismic effects.

Surface Testing, PMI and many others are available as well.

Recent Projects

Our valves and manifolds are installed in all sectors of a Nuclear Power Plant. As a safety-related classified valve or not safety-related non-classified item we are present in Nuclear Power Plant's all over the globe.

Fangchenggang Nuclear Power Plant; China
Hongyanhe Nuclear Power Plant; China
Ningde Nuclear Power Plant; China
YanJiang Nuclear Power Plant; China
Hainan Nuclear Power Plant; China
ShiDaoWan Nuclear Power Plant; China
Taishan Nuclear Power Plant; China

Fuqing Nuclear Power Plant; China
Zhangzhou Nuclear Power Plant; China
Pakistan Karachi Nuclear Power Plant; Pakistan
Laguna Verde Nuclear Power Plant; Mexico
Kozloduy Nuclear Power Plant; Bulgaria
Paks Nuclear Power Plant; Hungary

Primary circuit

- PWR-CNP 600 Reactor of 2nd Generation
- EPR Reactor of 3rd Generation
- ACP1000 Reactor of 3rd Generation
- Hualong One/HPR1000 Reactor of 3rd Generation
- HTR-PM Reactor of 4th Generation

Secondary circuit

- CPR 1000 Reactor of 2nd Generation
- VVER V-213 Reactor of 1st Generation
- VVER V-320 Reactor of 2nd Generation
- BWR-5 Reactor of 3rd Generation

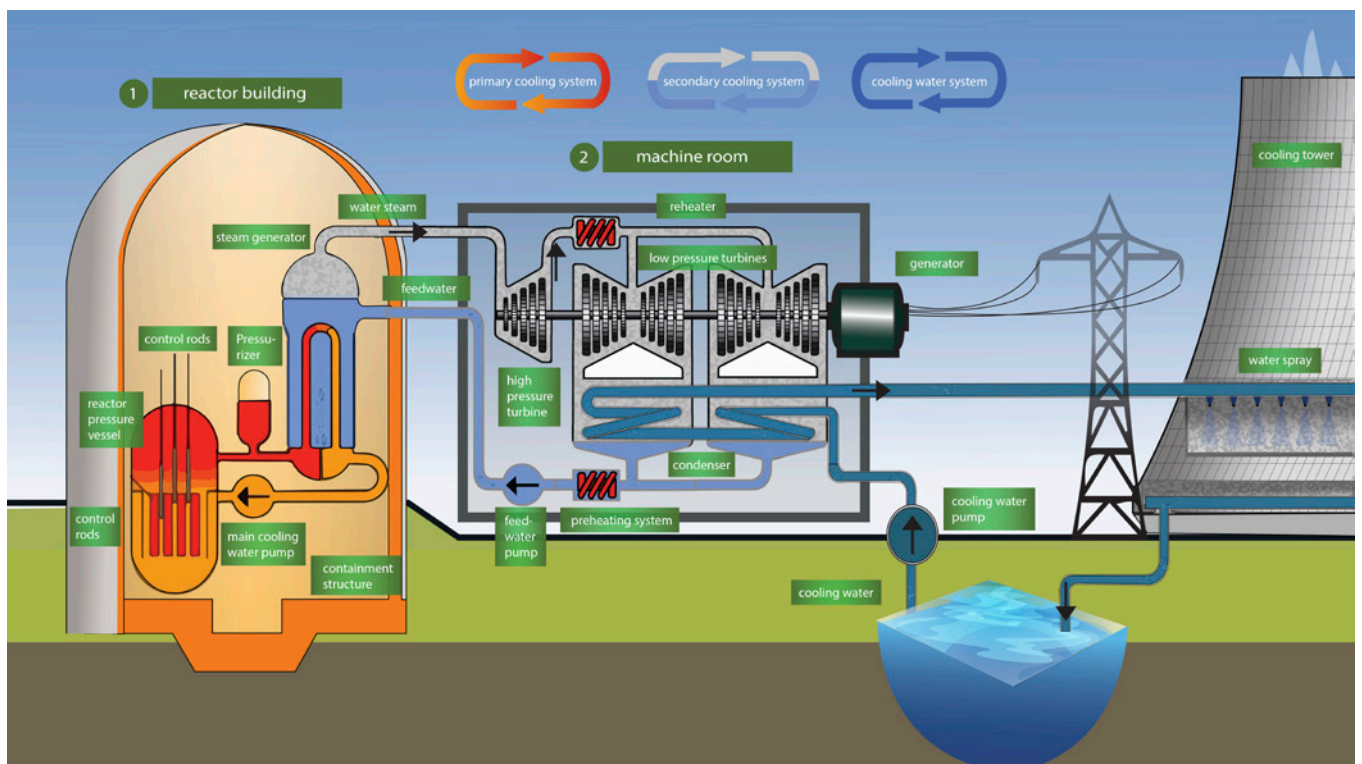

YOUR GLOBAL PARTNER

for Instrumentation and
Double Block & Bleed Valves



Visit us on:



ARMATURENFABRIK FRANZ SCHNEIDER GMBH + CO. KG
World Headquarters
Bahnhofplatz 12, 74226 Nordheim, Germany
Tel: +49 7133 101-0
www.as-schneider.com



ARMATURENFABRIK FRANZ SCHNEIDER SRL
Gradinari 32-38, 100404 Ploiesti
Romania
Tel: +40 244 384 963
www.as-schneider.ro



AS-SCHNEIDER ASIA-PACIFIC PTE. LTD.
970 Toa Payoh North, #02-12/14/15, Singapore 318992,
Singapore
Tel: +65 62 51 39 00
www.as-schneider.sg



AS-SCHNEIDER AMERICA, INC.
17449 Village Green Dr, Houston, TX 77040
United States of America
Tel: +1 281 760 1025
www.as-schneider.com



AS-SCHNEIDER MIDDLE EAST FZE
P.O. Box 18749, Dubai
United Arab Emirates
Tel: +971 4 880 85 75
www.as-schneider.ae



AS-SCHNEIDER INDIA PTE. LTD.
6/968U3 MN's Avenue, YMCA Calicut- 673001
Kerala, India
Tel: +91 999 544 2201
www.as-schneider.com

