

# Instrumentation and DBB Valves

For Special Services



Hydrogen

Fugitive Emissions

Special Media

TA-Luft 2021

ISO 15848-1

Low Temperature

Fire Safe

High-Pressure  
Requirements



# Contents

## Introduction

**Tackle your challenges - with our customized solutions. Whether you work with hydrogen blends or pure hydrogen, have to meet strict requirements regarding fugitive emissions, or are faced with further challenges such as arctic or high temperatures, high pressures or special media such as oxygen - we provide the right solution for you. Challenge us and benefit from our know-how!**

For more than two decades, AS-Schneider has been offering a wide range of valves suitable for hydrogen, which are used in areas such as generation, distribution, storage as well as in instrumentation and process control worldwide.

Our expertise in fugitive emissions has also been established for over a decade. As early as 2011, we received the first ISO 15848-1 certificate and have thus been meeting the requirements of the new TA-Luft not just today, but basically for more than 10 years.

Apart from meeting the strict requirements regarding hydrogen and fugitive emissions (TA-Luft and ISO 15848-1), we also support a variety of other specific requirements.

## Contents

<b>Introduction</b>	page 2
<b>Contents</b>	page 2
<b>Hydrogen compliant Instrumentation Valves &amp; DBB Piping Ball Valves</b>	page 3-5
Design Types	page 3
Hydrogen Options	page 3
Hydrogen compliant Metallic Materials and Sealing Materials	page 4
Hydrogen compliant Valve Head Units	page 5
Ordering Information	page 5
<b>Instrumentation Valves &amp; DBB Valves for Use with Fugitive Emissions</b>	page 6-8
Portfolio Overview for Use with Fugitive Emissions	page 6
Valve Head Units for Use with Fugitive Emissions	page 7
Sealing Systems for Use with Fugitive Emissions	page 7
Sealing Systems and their Classification for Use with Fugitive Emissions	page 8
<b>Further Special Service Valves</b>	page 9
<b>Notes</b>	page 10

## Design Types

You can select the valve from our extensive range of instrumentation, process or piping valves with a variety of connection options. This ensures optimum assembly and function in your application.

If you do not find what you are looking for or require modifications in terms of dimensions or connections, please contact your AS-Schneider representative.

## Hydrogen compliant Instrumentation Valves

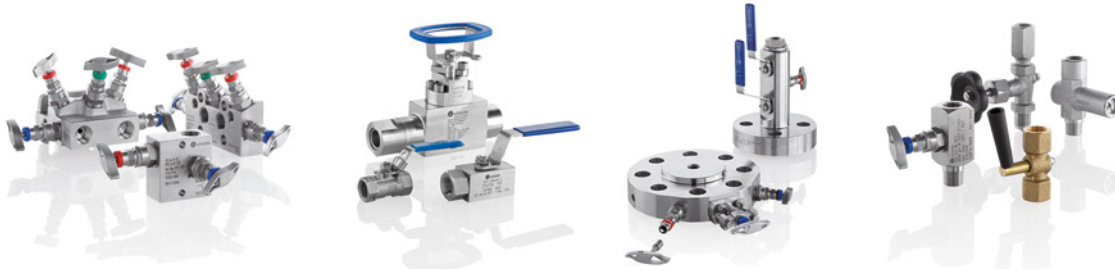

## Hydrogen compliant Double Block & Bleed Piping Ball Valves

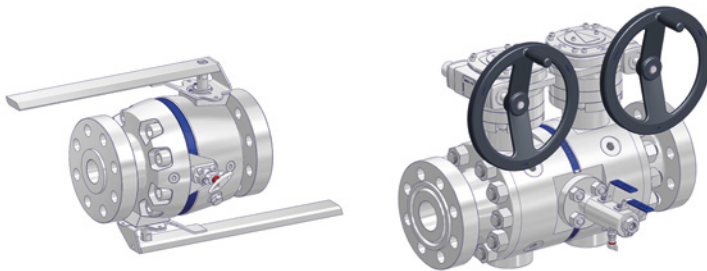

## Hydrogen Options

Customized to your needs, you can choose between 2 options that build on each other:

Recommended for open/ventilated environments

### W1 = Standard

When used in ventilated environments (open or forced ventilation), our cost-efficient standard valve inserts already meet the tightness requirements.

In the case of option **-W1**, the following actions are performed:

- 1 Acceptance Test Certificate 3.1 for wetted parts is provided.
- 2 We ensure that all metallic materials and sealing materials are suitable for use with hydrogen.

Recommended for closed/non-ventilated environments

### W2 = Increased tightness

In the case of option **-W2**, the following actions are performed:

- 1 Includes the requirements from option **-W1**.
- 2 Option **-W2** restricts the selection to suitable ISO 15848 Part 1 type-tested valve head units or bellows sealed head units.
- 3 Helium testing during series production in accordance with ISO 15848 Part 2 is performed for 10% of the parts.

## Additional Options | Requirements | Applications

Optionally, we're pleased to offer the following additional services:

- Advanced tests such as Hydrogen-Induced Cracking (HIC) test
- Applications in the cryogenic range ( $< -55^{\circ}\text{C}$  [ $-67^{\circ}\text{F}$ ])
- Mobile applicationen (e.g. bus, truck)
- High pressure applications ( $> 420$  bar [ $6,092$  psi]) [different test procedures will be applicable]
- And many more

# Hydrogen compliant Metallic Materials and Sealing Materials

## Hydrogen compliant Metallic Materials

Material	Operating Limits	Recommendation
<b>Unalloyed Steels (Carbon Steel)</b>		
ASTM A105	-29°C / +425°C (-20°F / +797°F)	Maximum utilization of the permissible stresses of 50%, or max. working pressure = 50% of the nominal pressure (see ASME B31.12, A-2.2).
ASTM A350 LF2	-46°C / +425°C (-51°F / +797°F)	
ASTM A106, Gr.B	-29°C / +425°C (-20°F / +797°F)	
<b>Austenitic Stainless Steels</b>		
1.4401/1.4404	-40°C / +538°C (-40°F / +1,000°F)	Recommended standard material.
316/316L	-40°C / +538°C (-40°F / +1,000°F)	
1.4571	-40°C / +538°C (-40°F / +1,000°F)	
<b>Cobalt Alloys</b>		
Stellite 4 / 6	-10°C / +550°C (14°F / +1,022°F)	Acceptable when abrasion or wear resistance is required.
<b>Brass</b>		
CW614N / CW617N	-196°C / +250°C (-321°F / +482°F)	
<b>Brass (deoxidized / oxygen free)</b>		
CW024A (SF-Cu) Deoxidized Copper	100% Hydrogen -269°C up to +250°C (-452°F / +482°F)	

## Hydrogen compliant Sealing Materials

Material	Operating Limits	Recommendation
<b>Engineering Plastics</b>		
PTFE	-40°C / +232°C (-40°F / +450°F)	Recommended by our hydrogen experts.
Reinforced PTFE	-40°C / +232°C (-40°F / +450°F)	
<b>Graphite</b>		
Graphite general	-200°C / +550°C (-184°F / +1,022°F)	
<b>O-Rings</b>		
FKM	-60°C / +232°C (-76°F / +450°F)	Temperature range depending on type.
EPDM	-40°C / +120°C (-40°F / +248°F)	
<b>Metallic Bellows</b>		
1.4571	-50°C / +538°C (-58°F / +1,000°F)	

# Hydrogen compliant Valve Head Units and Ordering Information

## Valve Head Units for Hydrogen Service

Enclosed is our selection of robust and durable valve head units - the perfect solution for the many challenges in the hydrogen industry. Our valve head units set the standard for quality and performance.

**OUR SYMBOL OF TRUST -  
YOUR PROMISE OF SAFETY.**



**Standard  
Valve Head Unit**

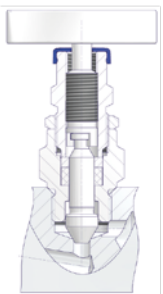

**ISO FE  
Type 1, 3 and 4**

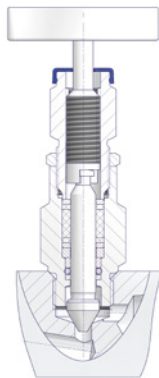

**OS&Y ISO FE  
Type 1, 3 and 4**

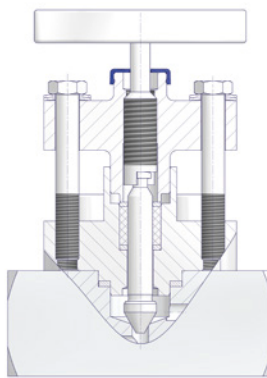

**Bellows**

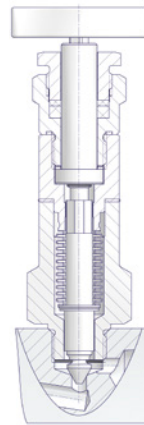

**Ball Valve  
KB ISO FE**



## Selection in the respective order information

Based on our respective product catalogs, among other things, the valve is selected according to function, pressure and temperature requirements, connections!

By selecting one of the two hydrogen options (-W1 or -W2) in the respective order information, it is ensured that all basic safety requirements for an H2 application are met. This includes both the appropriate material selection (metal, seal materials, lubricants) and processes such as welding and appropriate pressure tests.



Hydrogen:  
Products & Services



# Fugitive Emissions - Portfolio Overview

## Effective Control of Fugitive Emissions

The effective control of fugitive emissions in valves is a challenging task. We, at AS-Schneider, have established ourselves as experts in the field of fugitive emissions for over a decade. Our products are available with ISO 15848-1 and TA-Luft option according to the amendment (status 2021) and have been certified by TÜV Süd.

## ISO 15848-1 - International Standard

ISO 15848-1 is a globally recognized standard that provides the user with objective evaluation criteria for the classification of valves (shut-off and control devices). Its main objective is to enable the comparability of different designs and manufacturers of valves. Our valves meet the requirements of ISO 15848-1 and thus offer you a reliable solution for your process control.

## TA-Luft amendment 2021 - German Regulation

On December 1, 2021, the amended Technical Instructions on Air Quality Control (TA-Luft) came into force. The amended edition of Germany's central set of regulations sets stricter limits for pollutant emissions from facilities subject to immission control approval. Nationwide, more than 50,000 plants are affected by the amendment.

A significant change in valve specifications is the adoption of the ISO 15848-1 standard, which specifies the test procedures for valves and defines the parameters for their classification.

## Products for Use with Fugitive Emissions

Our product range includes valve head units for E Series Valves and Manifolds, Monoflanges, Ball Valves and VariAS-Blocks. As early as 2011, we received the first ISO 15848-1 certificate and have thus met the requirements of the new TA-Luft not only today, but basically for more than 10 years.

**OUR SYMBOL OF TRUST -  
YOUR PROMISE OF SAFETY.**



**E Series Valves and Manifolds**

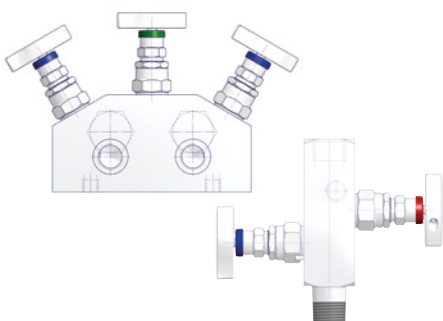

**Monoflanges**

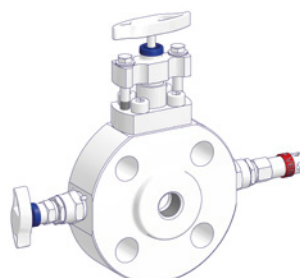

**VariAS-Blocks and Ball Valves**

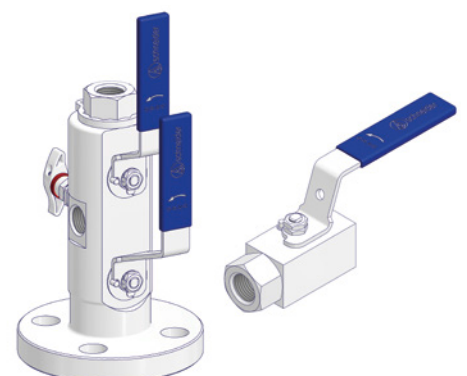

# Fugitive Emissions - Valve Head Units & Sealing Systems

## Valve Head Units for Use with Fugitive Emissions

We offer a wide range of valve head units and sealing systems for use with fugitive emissions. All of our valve head units meet the requirements of ISO 15848-1 and TA-Luft and are compliant with the TA-Luft amendment of 2021.

A detailed selection of available sealing systems and their classification for use with fugitive emissions can be found on the next page of the catalog.

**Standard  
Valve Head Unit  
ISO FE Type 4**

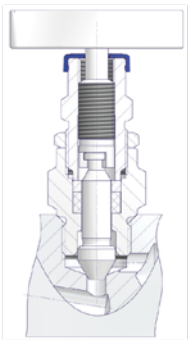

**Needle Valve  
ISO FE Type 1 & 3**

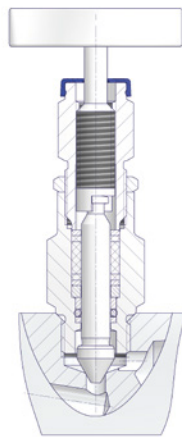

**OS&Y Needle Valve**

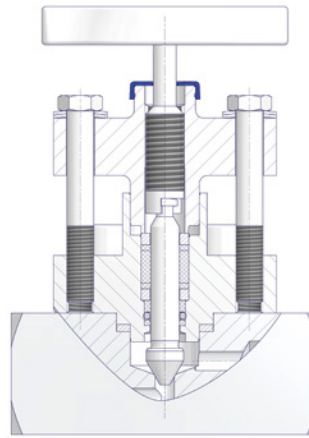

**Bellows Sealed  
Head Unit**

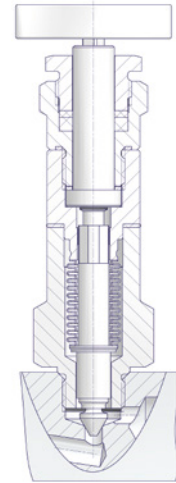

## Sealing Systems for Use with Fugitive Emissions

Since the tightness class is already specified in the TA-Luft and thus cannot be selected individually, we recommend that you consider the following three criteria for determining the optimal solution:

**1 Chemical Resistance:** Check possible restrictions regarding the seal material (PTFE, graphite, FKM elastomer, bellows). It is important to ensure that the selected seal material meets the specific requirements of your application.

**2 Endurance Class:** Although the TA-Luft does not give any specific information on the strength class, it still requires tightness in the long term and specifies that requirements for testing and maintenance of the sealing systems must be defined in management instructions. To reduce maintenance requirements, AS-Schneider valves are designed to be maintenance-free under certain conditions.

An example of this is instrumentation valves with strength class CO1 (205 mechanical cycles), which can be considered maintenance-free over a 30-year period if they are operated no more than 7 times per year (205 cycles / 30 years = 6.8 cycles per year). If a higher operating frequency is required, it is advisable to choose a solution with a higher strength class.

**3 Pressure and Temperature:** Make sure that the certified pressure and temperature range of the valves is sufficient for your specific application. It is essential that the valves can withstand the operating conditions to ensure reliable and safe operation.

# Fugitive Emissions - Available TA-Luft Sealing Systems & Classification

## Available TA-Luft Sealing Systems and their Classification for Use with Fugitive Emissions

Our products ensure the highest quality and reliability to meet the requirements of your plants.

The performance data listed here have been certified by a type test according to ISO 15848-1 in the presence of TÜV Süd. If you have any questions or are interested, please do not hesitate to contact us.

AS-Schneider Type	Sealing Material	Max. Pressure	Temperature Range	Endurance Class / Mechanical Cycles
<b>Screwed-in Valve Head Units</b>				
E Series	PTFE	420 bar (6,092 psi) Test Fluid Helium	-29°C / +82°C (-20°F / +180°F)	C01 / 205
		207 bar (3,000 psi) Test Fluid Methan	-29°C / +93°C (-20°F / +200°F)	CO2 / 1,500
E Series	Graphite	420 bar (6,092 psi)	-29°C / +82°C (-20°F / +180°F)	C01 / 205
ISO FE Type 1*	FPM-O-Ring + Graphite Packing	420 bar (6,092 psi)	-29°C / +200°C (-20°F / +392°F)	C01 / 1,500
ISO FE Type 3	PTFE / Carbon filled PTFE	420 bar (6,092 psi)	-29°C / +200°C (-20°F / +392°F)	C01 / 1,500
ISO FE Type 4	Graphite Packing	420 bar (6,092 psi)	-50°C / +400°C (-58°F / +752°F)	C01 / 205
<b>OS&amp;Y Valve Head Units</b>				
ISO FE Type 1 (OS&Y)	FPM-O-Ring + Graphite Packing	420 bar (6,092 psi)	-29°C / +200°C (-20°F / +392°F)	C01 / 205
ISO FE Type 3 (OS&Y)	PTFE / Carbon filled PTFE	420 bar (6,092 psi)	-29°C / +200°C (-20°F / +392°F)	C01 / 2,500
ISO FE Type 4 (OS&Y)	Graphite Packing	420 bar (6,092 psi)	-50°C / +400°C (-58°F / +752°F)	C01 / 205
<b>Bellows Sealed Valve Head Units</b>				
Bellows	Metallic Bellows with Safety Stuffing Box.	250 bar (3,626 psi)	Meets the requirements of the TA-Luft without proof.	
<b>Ball Valves</b>				
KB1-, KB3-, KC1-, KC3- with XCE Sealing System	Carbon filled PTFE	420 bar (6,092 psi)	-29°C / +40°C (-20°F / +104°F)	C01 / 205
KB2-, KB4-, KC2-, KC3- with XCD Sealing System	Primary Seal: Carbon filled PTFE and Graphite Packing	420 bar (6,092 psi)	-29°C / +40°C (-20°F / +104°F)	C01 / 205
<b>VariAS-Blocks</b>				
VariAS-Block with XCD Sealing System	Primary Seal: Carbon filled PTFE; Graphite Packing	420 bar (6,092 psi)	-29°C / +200°C (-20°F / +392°F)	C01 / 205
VariAS-Block with XCE Sealing System	Primary Seal: Carbon filled PTFE and PTFE Packing	420 bar (6,092 psi)	-29°C / +200°C (-20°F / +392°F)	C01 / 205

\* In this version, the packing was retightened 1x in the specified temperature range during the test. No readjustment was required in the temperature range -29°C to +40°C (-20°F to +104°F).



Fugitive Emissions:  
Products & Services



## Further Special Service Valves

We are your partner for all-in solutions! In addition to competent fulfillment of hydrogen and fugitive emission requirements (ISO 15848-1 and TA-Luft), we offer you much more.

With our extensive expertise, we can support you with a wide range of other specific requirements. No matter what challenges you want to tackle, we are ready to support you during implementation and offer customized solutions for your individual needs.

Below are some current examples from our wide range of services that cover specific requirements:

- Special Acid Gases acc. NACE
- Oxygen
- Chlorine
- Phosgene
- Isocyanate
- Respiratory Gas acc. DSIS 7573
- Low Temperature (Arctic Down to Cryogenic)
- High-Pressure Requirements (up to 15.000 psi)
- Fire-Safe Approved and by Design
- and much more



**PLEASE DO NOT HESITATE TO CONTACT  
YOUR SALES REPRESENTATIVE!**

Let us advise you  
non-binding advice!







# YOUR GLOBAL PARTNER

for Instrumentation and  
Double Block & Bleed Valves



Visit us on:



ARMATURENFABRIK FRANZ SCHNEIDER GMBH + CO. KG  
World Headquarters  
Bahnhofplatz 12, 74226 Nordheim, Germany  
Tel: +49 7133 101-0  
[www.as-schneider.com](http://www.as-schneider.com)



ARMATURENFABRIK FRANZ SCHNEIDER SRL  
Gradinari 32-38, 100404 Ploiesti  
Romania  
Tel: +40 244 384 963  
[www.as-schneider.ro](http://www.as-schneider.ro)



AS-SCHNEIDER ASIA-PACIFIC PTE. LTD.  
970 Toa Payoh North, #02-12/14/15, Singapore 318992,  
Singapore  
Tel: +65 62 51 39 00  
[www.as-schneider.sg](http://www.as-schneider.sg)



AS-SCHNEIDER AMERICA, INC.  
17449 Village Green Dr, Houston, TX 77040  
United States of America  
Tel: +1 281 760 1025  
[www.as-schneider.com](http://www.as-schneider.com)



AS-SCHNEIDER MIDDLE EAST FZE  
P.O. Box 18749, Dubai  
United Arab Emirates  
Tel: +971 4 880 85 75  
[www.as-schneider.ae](http://www.as-schneider.ae)



AS-SCHNEIDER INDIA PRIVATE LIMITED  
Rathinam Techzone Campus, Eachanari  
641021 Coimbatore, Tamil Nadu, India  
Tel: +91 999 544 2201  
[www.as-schneider.com](http://www.as-schneider.com)

